

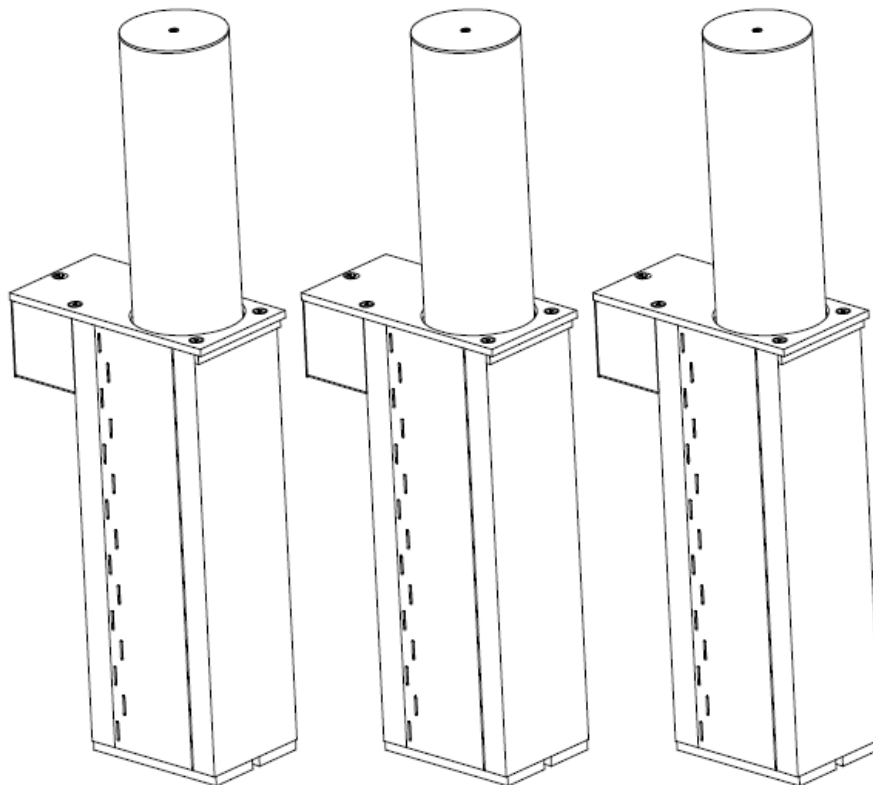

MODEL B-30 SERIES HYDRAULIC BOLLARD

INSTALLATION AND OPERATIONS MANUAL



B&B ARMR CORPORATION
CORPORATE OFFICE & TECHNICAL SUPPORT
2009 CHENAULT DRIVE
CARROLLTON, TX 75006
SUITE 114
PHONE: (800) 367-0387
FAX: (972) 385-9887

E-mail: info@bb-armr.com
techsupport@bb-armr.com
MADE IN THE USA



Your safety is extremely important to us. If you have any questions or are in doubt about any aspect of the equipment, please contact us.

INTRODUCTION

Welcome!

Congratulations on your purchase of a B&B ARMR vehicle barrier. In addition to providing detailed operating instructions, this manual describes how to install, maintain, and troubleshoot your vehicle barrier. If you require additional assistance with any aspect of your vehicle barrier's installation or operation, please contact us.

With years of experience in all aspects of perimeter security and related disciplines, our products are used throughout the world to control access and to protect people, equipment, and facilities. We offer a broad range of vehicle barrier and related security services:

- Turnkey installations
- Routine barrier preventative maintenance or emergency repairs (including work on non-B&B ARMR products)
- Spare or replacement parts
- Custom designs or special installations
- Equipment upgrades (modernize your old equipment with state-of-the-art hydraulics and control systems)
- Ancillary security equipment such as security guard enclosures, card readers, security lighting, and many other security related products.
- Technical support via telephone and possible on site support with advanced scheduling.

Safety



SYMBOL MEANING:



The lightning flash with arrowhead symbol, within an equilateral triangle, is intended to alert the user to the presence of non-insulated "dangerous voltage" within the product's enclosure that may be of sufficient magnitude to constitute a risk of electric shock to persons.



The exclamation point within an equilateral triangle is intended to alert the user to the presence of important operating and maintenance (servicing) instruction in the literature accompanying the product.

B&B ARMR does not assume responsibility for injury to persons or property during installation, operation, or maintenance. As the user, you are responsible for correct and safe installation, operation, and maintenance of this equipment. Users must follow the specific instructions and safety precautions located in this manual. In addition they must: Follow the safety standards of the Occupational Safety and Health Administration (OSHA), as well as other applicable federal, state, and local safety regulations and industry standards and procedures. For installation outside the United States, users must also follow applicable international, regional, and local safety standards. Engage only trained and experienced staff to install, operate, and maintain the equipment. Ensure that all repairs are performed correctly, using properly trained technicians and the correct tools and equipment.

Additional safety devices may be included with this barrier system:

- Vehicle loop detector(s) – Safety loop
- Traffic arms
- Traffic lights

How to Contact Us

B&B ARMR works with an extensive list of value added resellers to best support our customers. Our resellers offer not only our superior products, but provide excellent support. If you should need advanced assistance with your vehicle barrier or would like further information on any physical security applications please contact us at:

CORPORATE OFFICE & TECHNICAL SUPPORT:

2009 CHENAULT DRIVE
CARROLLTON, TX 75006
SUITE 114
PHONE: (800) 367-0387
FAX: (972) 385-9887

FIELD SUPPORT OFFICE:

1934 OLD GALLOWS ROAD
VIENNA, VA 22182
PHONE: (703) 752-6108
FAX: (703)752-6288

**E-mail: info@bb-armr.com
techsupport@bb-armr.com**

Table of Contents

INTRODUCTION.....	ii
Safety.....	ii
How to Contact Us.....	iii
1 ORIENTATION.....	5
<i>1.1 Overview.....</i>	<i>5</i>
1.1.1 Hydraulic Cylinder.....	7
1.1.2 Cylinder Weldment Assembly.....	7
1.1.3 Tube Cover Plate.....	7
1.1.4 Proximity Switch Bracket.....	7
1.1.5 Housing Weldment.....	8
1.1.6 Collision Pins.....	8
1.1.7 Cover Plate.....	8
1.1.8 Guide Strip.....	8
1.1.9 Up Line Hose.....	8
1.1.10 (Item 14) Proximity Cable.....	8
1.1.11 (Item 22) Proximity Switch.....	8
1.1.12 Options.....	8
2 INSTALLATION.....	9
<i>2.1 Introduction.....</i>	<i>9</i>
<i>2.2 Environmental Conditions.....</i>	<i>9</i>
<i>2.3 Site Preparation.....</i>	<i>10</i>
<i>2.4 Positioning.....</i>	<i>11</i>
<i>2.5 Rebar and Conduit Installation.....</i>	<i>12</i>
<i>2.6 Concrete.....</i>	<i>13</i>
<i>2.7 Hydraulic Connections (Automatic Bollards Only).....</i>	<i>13</i>
<i>2.8 Typical Hydraulic Flow Diagram.....</i>	<i>14</i>
<i>2.9 Proximity Switch Connection.....</i>	<i>14</i>
<i>2.10 Optional Pad Heater or Heater Strip.....</i>	<i>15</i>
<i>2.11 Final Pre-operation Checklist.....</i>	<i>15</i>
3 OPERATION.....	15
<i>3.1 Introduction.....</i>	<i>15</i>
<i>3.2 Control.....</i>	<i>16</i>
<i>3.3 Operating Time.....</i>	<i>16</i>
4 MAINTENANCE.....	17
<i>4.1 Introduction.....</i>	<i>17</i>

4.2	<i>Spare Parts</i>	17
4.3	<i>Monthly Inspections</i>	18
4.4	<i>Six-Month Inspections</i>	19
4.5	<i>Annual Maintenance Inspections</i>	19
5	TROUBLESHOOTING	19
5.1	<i>B-30 Troubleshooting Guide</i>	19
6	WARRANTY	22
7	APPENDIX	23
7.1	<i>Semi-Automatic Parts Breakdown</i>	23
7.2	<i>Equipment Maintenance Log Form</i>	25
7.3	25

1 ORIENTATION

1.1 Overview

-The model B-30 Hydraulic Bollard system is designed to act as a vehicular deterrent for perimeter security and traffic control purposes. Engineered for simple installation, fast service and easy relocation, the Model B-30 is constructed of high strength steel cylindrical units guided by an offset flange assembly with precision machined anti-friction surfaces. The Model B-30 is offered in a variety of drive solutions: Automatic (HPU Driven), Semi-automatic (Manual) and fixed are the standard drive options available.

The bollard system has been tested to Department of State specifications STD 02.01.

The bollard system is designed to stop a 15,000-pound vehicle traveling at 40 mph.

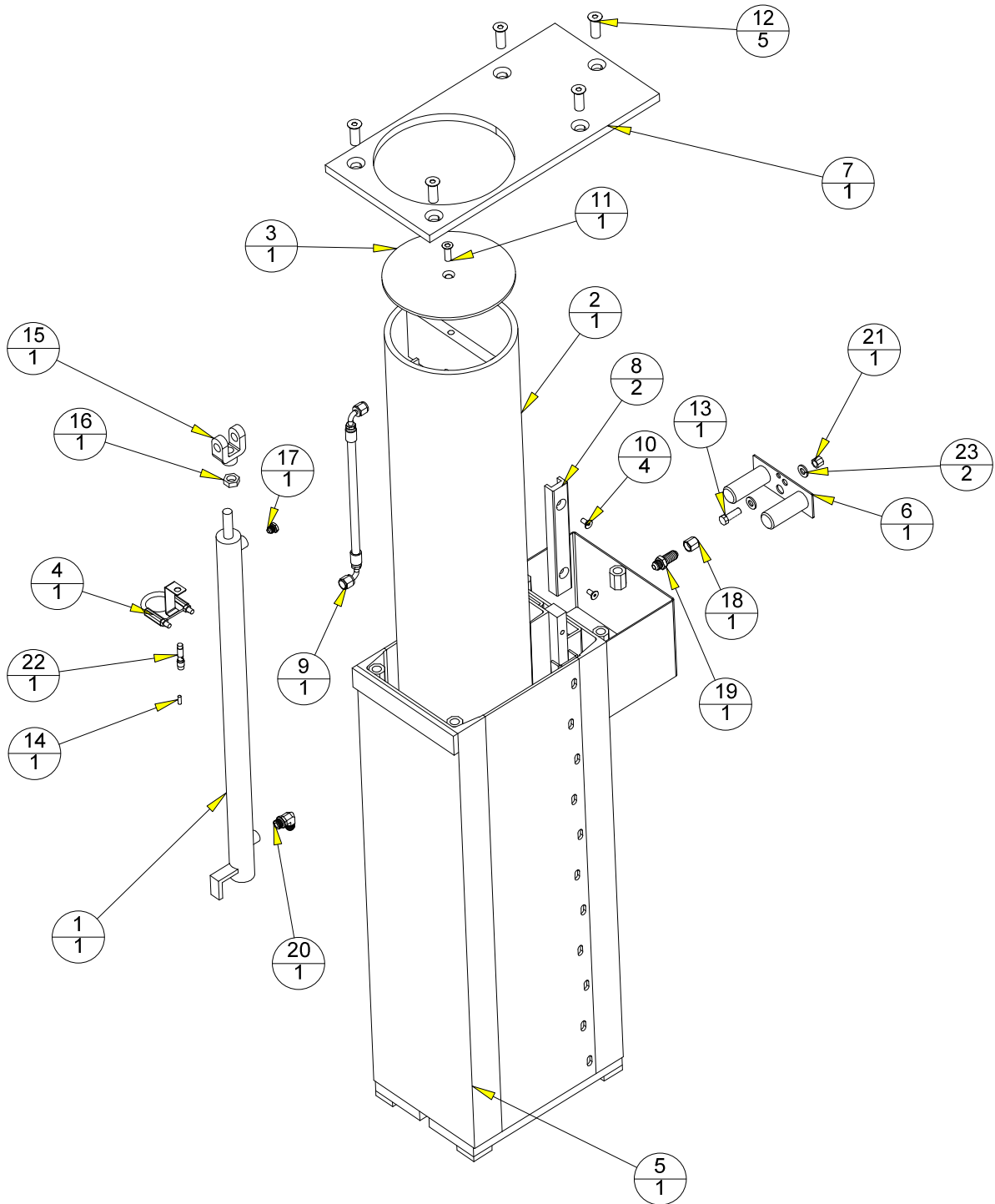

**Figure 1: Model B-30 Bollard Frame (Automatic Product Shown)
(See Appendix for Semi-Automatic Parts List)**

2	23	XWASH-98023A033, MCMaster	WASHER, 1/2", 1.062" X .532" X .122"	
1	22	XPROX-FCM2-1204, HTM FCM2-1204C-AR S4	PROXIMITY SWITCH	
1	21	XNUT-9561A210, MCMaster	HEX NUT, NYLON, 1/2"-13	
1	20	XFTI-8-C5OX-S	90 ELBOW, #8 SAE TO #8 JIC	
1	19	XFIT-8_WTX-S	BULKHEAD UNION, 3/7 FLARE 87 FLARE, 1/2	
1	18	XFIT-8-FNTX-S	CAP, FEMALE, 1/2 JIC	
1	17	XFIT-6-P50N, PARKER HANNIFIN 6-P50N	PLUG, MALE, 3/8 SAE	
1	16	XCLEVIS-NUT, MCMaster 94846A540	HEX NUT 3/4-16UNC	
1	15	XCLEVIS-1A347	CLEVIS MOUNT, AUTO	
1	14	XCABLE-4-FS4TZ, HTM RFS4TZ-V072	PROXIMITY CABLE	
1	13	XBOLT-92865A716, MCMaster	HEX BOLT, GRADE 5, 1/2"-13 X 1.5" LG	
5	12	XBOLT-1215, 3/4-10 X 1.5" LNG, FSH	3/4-10 X 1.5" LONG, FLATHEAD, SOCKET DRIVE	
1	11	XBOLT-0815, 1/2-13 X 1.5" LNG, FSH	1/2-13 X 1.5" LONG, FLATHEAD, SOCKET DRIVE	
4	10	XBOLT-0607, 3/8-16 X .75" LNG, SST	3/8-16 X .75" LONG, FLAT, SOCKET DRIVE SST	
1	9	B30-2-008	UP LINE HOSE B30-BOLLARD	
2	8	B30-3129	GUIDE STRIP DELRIN B30-BOLLARD	
1	7	B30-3126	COVER PLATE AUTOMATIC B30-BOLLARD	
1	6	B30-2147	COLLISION PIN ASSEMBLY B30-BOLLARD	
1	5	B30-2141	HOUSING WELDMENT AUTOMATIC B30-BOLLARD	
1	4	B30-2120	PROXIMITY SWITCH HOLDER ASSEMBLY B30-BOLLARD	
1	3	B30-2110	TUBE COVER PLATE ASSEMBLY B30-BOLLARD	
1	2	B30-2106	CYLINDER WELDMENT ASSEMBLY B30-BOLLARD	
1	1	B30-2006	HYDRAULIC CYLINDER B30-BOLLARD	
QTY	FIG NO	PART OR IDENTIFYING NUMBER	NOMENCLATURE OR DESCRIPTION	NOTES

1.1.1 Hydraulic Cylinder

On the automatic system, the hydraulic cylinder provides the force when pressurized to raise or lower the bollard by a hydraulic pumping unit. On the semi-automatic product, this is a pre-pressurized gas cylinder to allow the bollard to be manually lifted and lowered.

1.1.2 Cylinder Weldment Assembly

The main structural element of the B-30 Bollard is the cylinder. This 10 inch schedule 80 steel cylinder raises and lowers to provide the obstruction during impact. When raised, the tube protrudes 30 inches of grade.



CAUTION: This barrier is made of heavy steel components. Ensure all personnel are cleared of area during operation.

1.1.3 Tube Cover Plate

The cover plate seals the top of the cylinder to provide a functional and aesthetic bollard. This cover plate is used to access the hydraulic cylinder and other maintenance items.

1.1.4 Proximity Switch Bracket

This bracket positions the proximity switch in the correct location to provide a feedback signal when the bollard is in the lowered position. The optional raised proximity switch is on the outside of the tube next to the fittings.

1.1.5 Housing Weldment

The housing provides the necessary structure to hold the bollard cylinder and position it when raising and lowering.

1.1.6 Collision Pins

The collision pins are used as the elements to hold the bollard cylinder into the housing during impact. These pins are easily removed to allow the entire bollard cylinder to be removed for maintenance and inspection.

1.1.7 Cover Plate

The access cover allows maintenance access to the system without physically removing the structure. Access to hydraulic cylinder, fittings, hoses and collision pins can be made by removal of this cover.

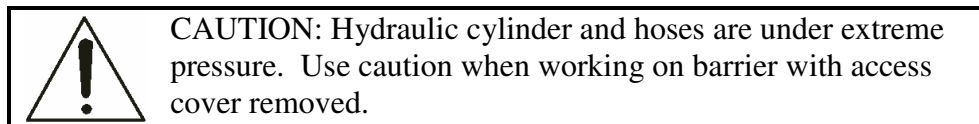

1.1.8 Guide Strip

The acetyl (Delrin) guide strips ensure the bollard cylinder can move freely with minimum maintenance required.

1.1.9 Up Line Hose

This hydraulic hose allows hydraulic fluid to be pressurized in the cylinder to raise or lower the bollard cylinder.

1.1.10 (Item 14) Proximity Cable

The proximity cable connects the proximity switch to the electrical system.

1.1.11 (Item 22) Proximity Switch

The proximity switch is used to provide an electrical signal back to the HPU to signify the bollard is in the lowered position. An optional proximity switched for the fully raised position is available.

1.1.12 Options

The B-30 Bollard System is available with a broad array of options and field installed kits. Consult your ordering documentation to determine whether your system has the optional equipment.

- Concrete Heater Kit. This optional kit includes the necessary components to add field installed heat trace cables around the support frame prior to installation. This is highly recommended for areas where ice or snow may inhibit the performance of the barrier.

- A traffic control gate arm to warn the vehicle operator. This gate arm is positioned on the attack side of the barrier and does not open to allow traffic until the barrier is fully lowered (stowed), and the gate lowers to block traffic before the barrier starts to rise (deploy).
- Red/amber traffic lights.
- Infrared safety beams to detect pedestrian traffic or as an additional vehicle sensing device.

2 INSTALLATION

2.1 Introduction

This section of the manual describes the procedure to set-up and configures the B-30 Bollard barrier for first-time operation. The product ships from the factory tested and ready for deployment following these steps. Normally bollard arrays or lanes consist of groupings of 3 bollards that operate in unison. Normal spacing is 48 inches center to center.

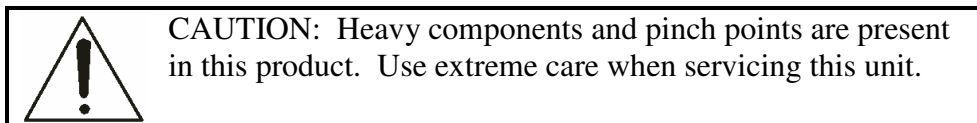
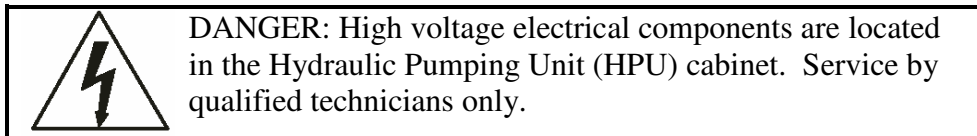

NOTE: The hydraulic hoses are constructed with JIC fittings to allow removal and installation without sealant. Care should be used when disconnecting the pressure side of the hose to insure the pressure has been released prior to disconnecting the fitting. The pressure can be relieved by activating the down control button and visually watching the cylinder shaft retract into the cylinder and the attack plate is in the completely lowered position.

2.2 Environmental Conditions

The B-30 bollard is engineered to work in many different applications globally. As with any movable barrier there are environmental conditions that should be met to keep the bollard system working optimally.

Do not use the bollard if:

- The bollard is flooded or underwater.

- The temperature is below 32°F unless the bollards were installed with concrete heaters and the HPU is equipped with an optional hydraulic fluid heater.
- The bollard is covered by excessive snow, sand or dirt.

2.3 Site Preparation

The Bollard's performance can be influenced by the surrounding soil conditions and grade. It is expected that the minimum soil compression force is 1600 PSI in and around the installation area. Please consult with B&B ARMR Technical Support if there are questions in regards to the installation site conditions.

The following lists some recommendations related to site choice and preparation:

1. The B-30 barrier is powered by hydraulic pressure from a remotely located Hydraulic Pumping Unit (HPU). It is critical that the HPU and the B-30 barrier be within proximity to ensure any pressure drop in the hydraulic lines is minimal. Consult B&B ARMR Technical Support if HPU location is further than 30 feet from barrier.
2. Soil compressive strength under barrier shall be a minimum of 1600 PSI. Compact and add gravel where necessary to ensure solid soil base. Consult B&B ARMR Technical Support if soil compressive strength does not meet this minimum requirement.
3. Install barrier in area that has adequate drainage. Barrier's operational performance is affected when there is inadequate drainage.
4. The barrier operates best when installed on a level surface. Level site side to side and front to back prior to barrier installation.
5. Excavate install site to accommodate a minimum concrete pad dimension shown to match the number of barriers you have purchased. If site excavation can not be completed per these minimum dimensions, please contact B&B ARMR Technical Support for a custom solution to meet the site requirements.
6. Installation of the lost casing is typically done prior to the installation of the bollard assembly.

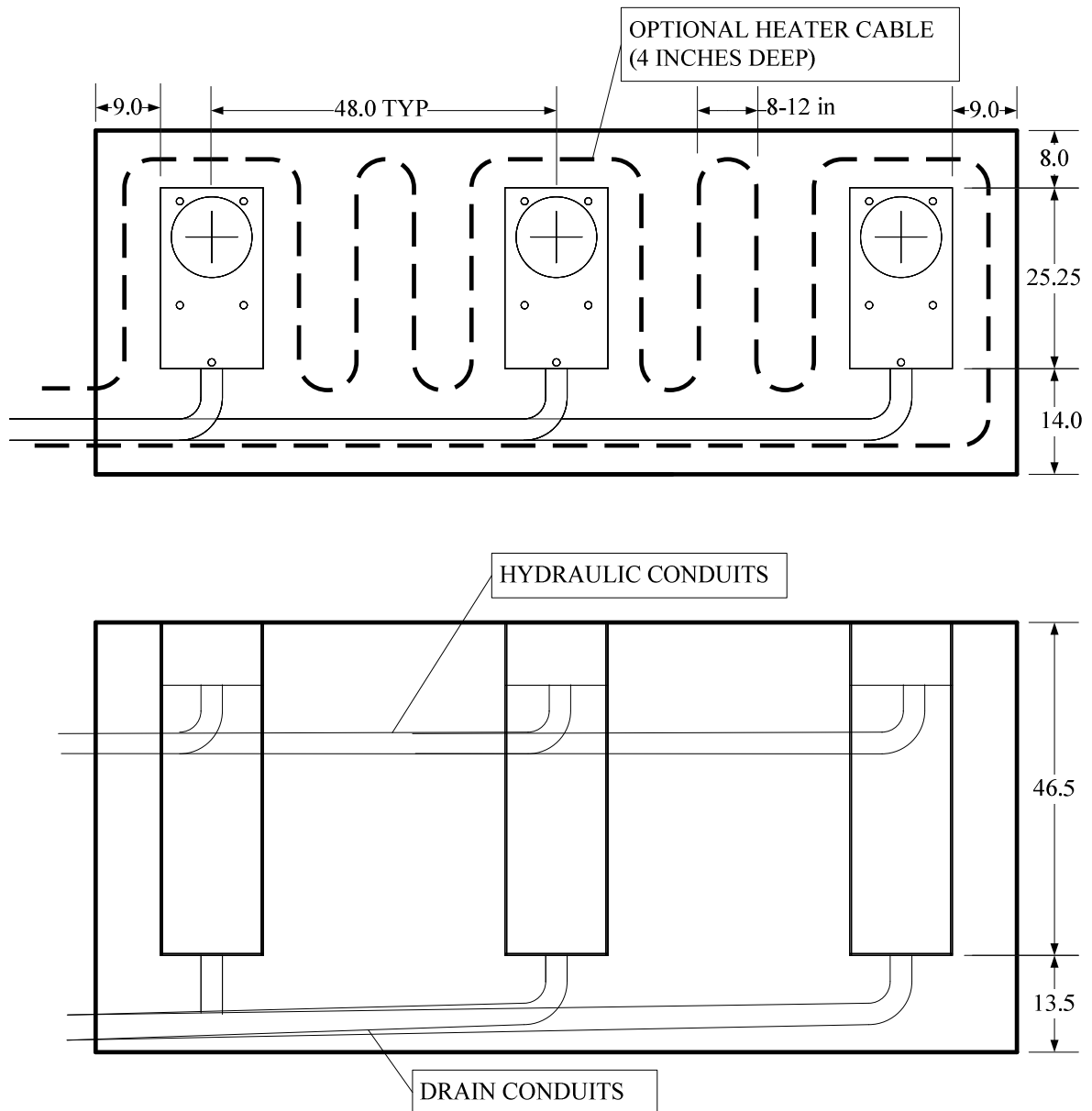

Figure 2 Barrier Concrete Pad Dimensions

2.4 Positioning

1. Position the lost casings to ensure top surfaces are level with finished site grade. A common technique to ensure casings are installed correctly includes using a wooden frame or timber to suspend the casings as the concrete is added. It is critical to the installation of the barrier that the lost casing is not twisted and does not get dimensionally changed during the install process. Additional wood support may be desired internal to the lost casing.

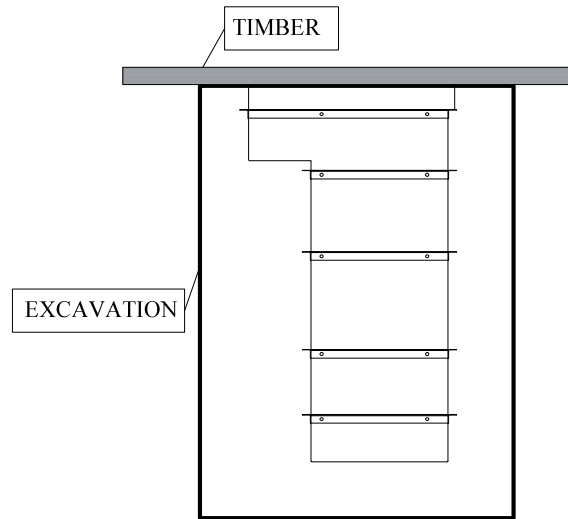

Figure 3 Lost Casing Installation

2.5 Rebar and Conduit Installation

1. Install drain conduits to enable positive flow away from barrier. Drain conduit holes are provided at the bottom of the lost casing. The drain conduit hole is 2.375" diameter.
2. Install hydraulic hose conduits utilizing clearance holes in the lost casing. Seal all unused conduit holes to ensure concrete does not enter casing volume. The clearance hole in the lost casing for the hydraulic conduits is 3.0" diameter.
3. A 1.0" conduit hole is provided to incorporate a conduit to run the proximity switch and/or heater wire terminations.

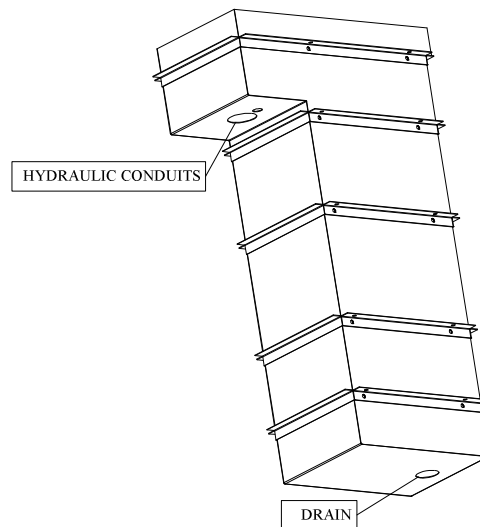

Figure 4 Lost Casing.

4. Set #4 rebar in 12” center cross patterns in excavation area. Slide rebar around lost casing ensure frame is rigidly attached to concrete pad. There is no need to weld the rebar to the frame.
5. If optional heater kit has been purchased, install heater core cable per kit instructions at this time.

2.6 Concrete

1. Concrete shall be rated at 3000psi or higher.
2. Assure concrete does not flow into casing area.
3. Finish concrete level to less than .125” of top surface of casing. The bollard after install will be slightly higher.
4. Vibrate concrete to assure all air bubbles and voids are removed under and around barrier.

2.7 Hydraulic Connections (Automatic Bollards Only)

Connect hydraulic lines through conduit to cylinder connection using JIC fittings. The fittings are tapered so the connections should not be over-tightened. As a reference, use environmentally safe oil Mobil EAL 224 or equivalent when adding hydraulic oil to the HPU.

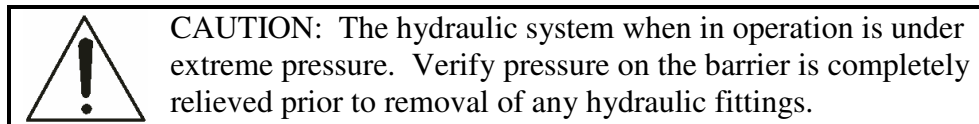

Prior to full operation the hydraulic lines and hydraulic cylinder must have its entrapped air bled out of the hydraulic cylinder.

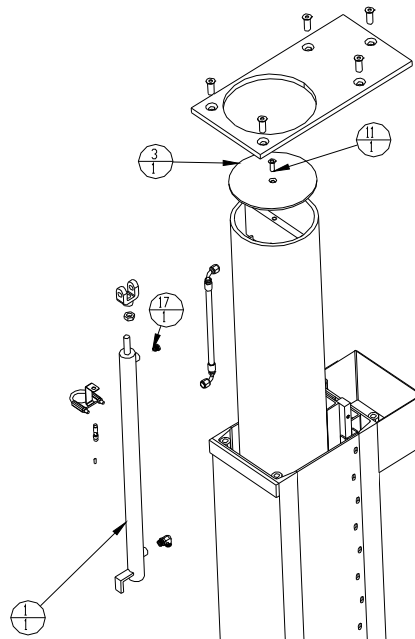

1. Remove the top cover of the bollard tube. Item 3.
2. Crack the plug fitting at the top of the hydraulic cylinder. Item 17. Be careful to secure any loose tools or components to avoid dropping them to the bottom of the bollard tube.
3. Close the flow control valves located beneath the directional control valve. This is done to better control the flow of fluid to the bollard.
4. Pressurize the HPU system to a maximum pressure of 200 psi by using the manual hand pump.
5. Manually or electrically apply an UP command to shift the valve and allow fluid pressurize the manifold.
6. Slightly loosen the flow control valve until you hear a slight amount of fluid traveling through the hose. Turn off HPU when visible signs of hydraulic fluid are shown at the cracked fitting. Retighten the cylinder plug.

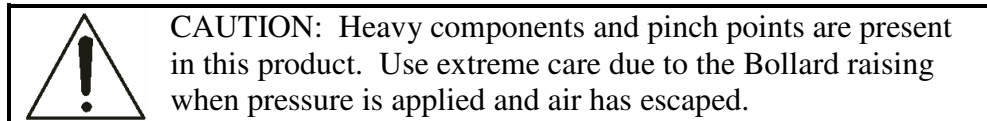

2.8 Typical Hydraulic Flow Diagram

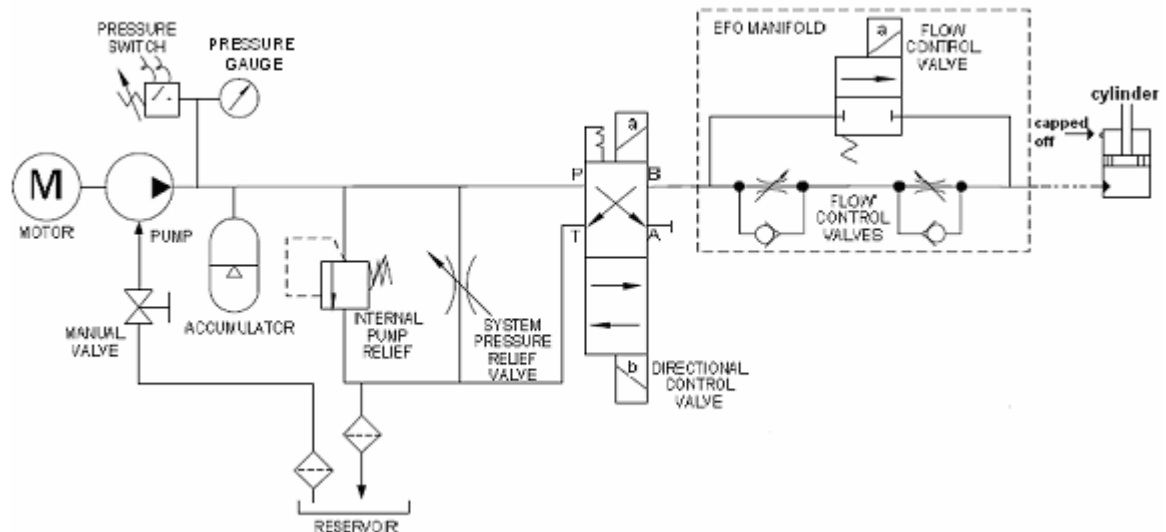

2.9 Proximity Switch Connection

The proximity switch is adjusted in the factory and should require no further adjustment. To connect the proximity switch, use the included proximity switch connector and screw onto back end of proximity switch. Route wires clear of cylinder travel and pinch points. Once power is applied, the proximity switch will show a red LED light on when switch is closed and no LED light when switch is open.

Proximity switch wire connections are shown in the following figure.

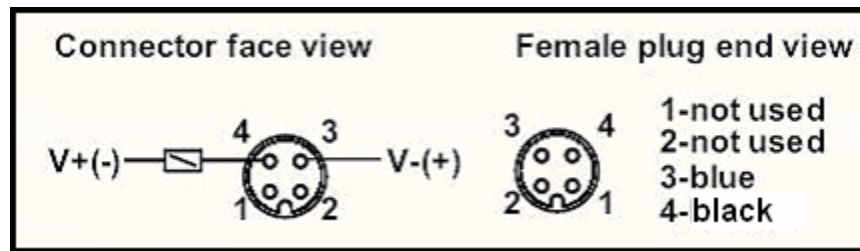

Figure 5 Proximity Switch Connections

2.10 Optional Pad Heater or Heater Strip

If so equipped, connect optional pad heater per heater kit instructions.

2.11 Final Pre-operation Checklist

Before operating the B-30 Bollard System, go through the checklist below and verify that each of these steps has been completed.

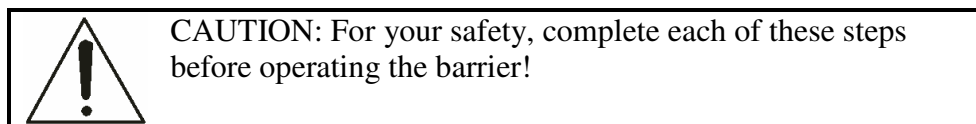

- Verify unit has hydraulic fluid to recommended level.
- Verify control unit is plugged in and cable is routed clear of barrier operation.
- Verify area is clear of personnel and other obstructions.
- Ensure supplied power to HPU matches product requirements.
- Verify electrical hookups are completed per electrical wiring diagram matching particular product.
- It is recommended the system be cycled 4 complete cycles prior to any vehicle or pedestrian traffic.

3 OPERATION

3.1 Introduction

On the automatic version of the B-30, the bollards are moved to the up (or protective) position with a single, center mounted hydraulic cylinder. When the bollards are in the raised position, the cylinder is maintained at the system pressure. The speed of operation is determined by the amount of pressurized hydraulic fluid able to pass to the bollards in

a given amount of time. This can be controlled by the flow control valves which are located in the hydraulic pumping unit.

The Semi-automatic bollard has a pressurized gas shock located where the hydraulic cylinder is located on the automatic version. The gas shock is engineered to provide a load balanced system that can be pulled up and pushed down manually.

3.2 Control

The automatic B-30 Bollard System is controlled by the flow of hydraulic fluid under pressure from the HPU to the cylinder. All control components are connected to the HPU.

The semi-automatic system operates by using the supplied key to unlock the bollard when it is in the down position. This frees the bollard to be raised and locked into place. Ensure the lock is fully engaged (key 90 degrees) when bollard is left in the fully up or down position.

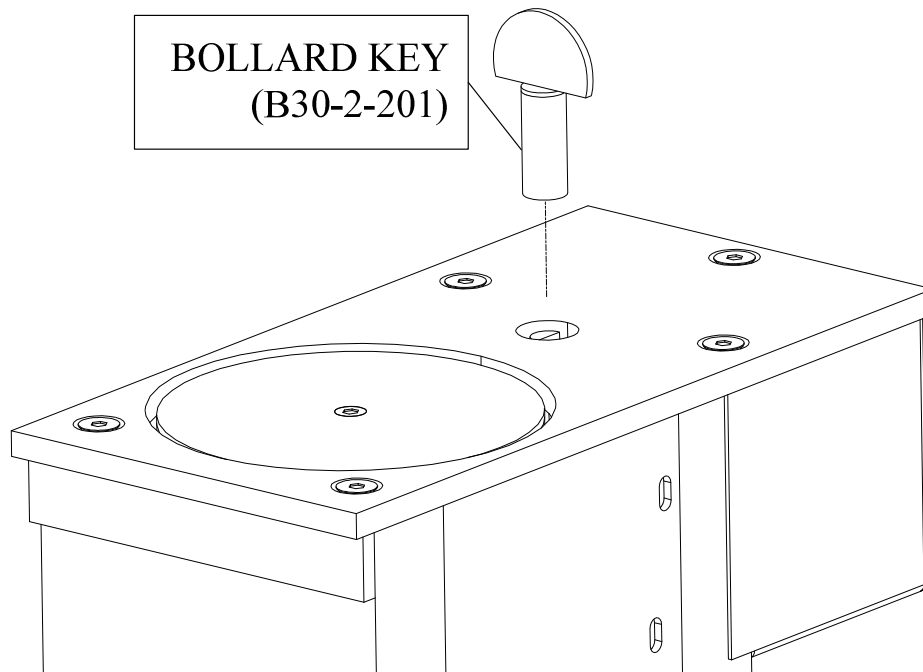

3.3 Operating Time

The operating time for the bollard system is field adjustable at the HPU by varying the hydraulic fluid flow from the HPU as required. Normal operation cycles range from 6-10 seconds for both up and down. Emergency fast Operation (EFO) is approximately 1.5-2 seconds. The following table illustrates the estimated required flow rates required to operate. These values are to use only for pump sizing and initial set-up. Actual times and pressures will vary in field level tests.

Pressure required to raise the bollard: 250 psi. (Does not include hose loss)

Time (Sec)	Actual Required Flow per Bollard (in ³ /sec)	Actual Required Flow per Bollard (gal/min)
1	53	13.8
2	27	6.9
3	18	4.6
4	13	3.4
5	11	2.8
6	9	2.3
7	8	2.0
8	7	1.7
9	6	1.5
10	5	1.4
11	5	1.3
12	4	1.1

4 MAINTENANCE



Do not attempt repairs unless you are trained and qualified. This vehicle barrier can cause equipment damage and severe injury if it is operated or maintained improperly.

4.1 Introduction

The B-30 Bollards are designed to be largely maintenance free. As with any complex electromechanical device, they must be regularly inspected to ensure they are operating correctly. A monthly visual inspection and a more thorough biannual inspection as described below are recommended. Please contact B&B ARMR Technical Service Support for assistance with inspections, maintenance, or repairs if needed.

Component damage is likely if a vehicle strikes the barrier. If this occurs, contact B&B ARMR. We can help you assess the damage to make sure there is no hidden damage that will compromise safety or effectiveness and help you determine which components should be replaced.

4.2 Spare Parts

There are few failure and wear items in the B-30 design. The following table shows several suggested spare parts based on wear and environmental (lightening) failure modes.

Qty	Part Number	Description	Failure Mode	MTBF Cycles
1	XPROX-FCM2-1204	Proximity Switch	Electrical	n/a
1	XCABLE-R-FA4TZ	Proximity Switch Cable	Electrical	n/a
2	B30-3129	Guide Strip, Delrin	Wear	200,000
1	B30-2006	Hydraulic Cylinder	Wear	200,000

4.3 Monthly Inspections

We recommend you perform the following visual inspections monthly on the barrier system. An equipment maintenance log is supplied in the appendix to assist in the logging.

- Verify and inspect the drains to make sure they are clear of obstructions.
- Inspect the guide rails for signs of uneven wear or contamination.
- Check all hydraulic fittings to make sure they are not leaking and are at the proper torque.



CAUTION: The hydraulic system when in operation is under extreme pressure. Verify pressure on the barrier is completely relieved prior to removal of any hydraulic fittings.

- Lubricate acetyl plastic bearing areas with a dry graphite powder.
- Inspect the condition of the finish. If rust is present, wire brush and sand the area then paint with a primer and a matching color.
- Vacuum and clean the pumping unit area.
- Check oil for level, pressure, and condition in the HPU. The level should be 1-1.5 inches below the top of the tank when bollards are in the lowered position (Recommended vegetable based oil: Mobil EAL 224).
- If oil is contaminated, investigate source of contamination and replace immediately (Recommended oil: Mobil EAL 224).
- Check barrier for operation through normal cycles.
- Adjust barrier speed to ensure proper operation.
- During the opening and closing cycles, verify the barrier operates smoothly and does not bind. Also verify that the barrier does not hit with excessive force when it contacts its full-open or full-closed positions. If necessary, adjust the barrier's speed.
- Check the hydraulic pumping unit for leaks at all points.
- Visually inspect the operation and electrical contacts.
- Tighten electrical contacts if required.
- Check, adjust, and tighten all sensors (limit switches, proximity switches).
- If applicable, check traffic lights and replace any burned bulbs or LEDs.
- Check safety devices (loop, IR, etc.) for proper operation and report any anomalies (if applicable).
- Lubricate all pivot points and the clevis pin.
- Inspect the cylinder.

- Check hoses for wear.
- Check the operation of the control panel(s).
- Check the control panel's buttons and lights for proper operation and replace if necessary.
- Update the operation and maintenance log.

4.4 Six-Month Inspections

We recommend you perform the following inspections every six months.

- Repeat the visual inspections in the monthly inspection list.
- Inspect the hydraulic system for signs of oil leaks.

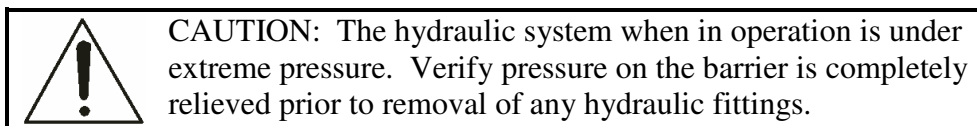

- Measure the resistance in any traffic loops and log the measurements.
- When the inspection is complete, turn the power on and test cycle the barrier to verify operation and control.
- Check the PLC for normal operation of all logic and functions.

4.5 Annual Maintenance Inspections

We recommend you perform the following inspections annually.

- Perform all quarterly maintenance steps.
- Replace the hydraulic filter & fluid.

5 TROUBLESHOOTING

The table below provides a general guidance on identifying and correcting any problems with your B-30 bollard system. If you encounter problems that you cannot fix, contact your local value added reseller or B&B ARMR and we will gladly work with you to correct them.

5.1 B-30 Troubleshooting Guide

The table below provides guidance on identifying and correcting any problems with your B-30 Bollard system. Please refer to the HPU O&M manual for more detailed troubleshooting guides referring to the pumping unit. If you encounter problems that you cannot fix, contact B&B ARMR and we will gladly work with you to correct them.

Symptom	Actions
Bollard does not raise	<ol style="list-style-type: none"> 1. Check power 2. Check overload protector

Symptom	Actions
	<ol style="list-style-type: none"> 3. Check pressure gauge 4. Manually raise the bollard by depressing the directional control valve to see if problem is mechanical or electrical. <p>Q. If mechanical:</p> <ol style="list-style-type: none"> 5. Check for binding between moving plate and frame. Check connection of linkage between frame and plate. Check for foreign debris. <p>Q. If not:</p> <ol style="list-style-type: none"> 6. Check PLC input 7. Check that safeties are clear 8. Check PLC output 9. Check push button operation
<p>Bollard does not close</p>	<ol style="list-style-type: none"> 1. Check power 2. Check overload protector 3. Check pressure gauge 4. Manually close the bollard by depressing the directional control valve to see if problem is mechanical or electrical. <p>Q. If mechanical:</p> <ol style="list-style-type: none"> 5. Check for binding between moving plate and frame. Check connection of linkage between frame and plate. Check for foreign debris under bollard cylinder. <p>Q. If not:</p> <ol style="list-style-type: none"> 6. Check PLC input 7. Check that safeties are clear 8. Check PLC output 9. Check push button operation
<p>HPU pump will not build up pressure but is running</p>	<ol style="list-style-type: none"> 1. Check power 2. Close pressure relief valve 3. Motor is running backwards (counter-clockwise). <i>Motor should be running clockwise.</i>
<p>HPU pump will not turn on</p>	<ol style="list-style-type: none"> 1. Check incoming power & power to motor 2. Check motor overload, press <i>start</i> 3. Check motor starter

Symptom	Actions
	<ol style="list-style-type: none"> 4. Check low level switch 5. Check pressure switch
Bollard makes noise during operation	<ol style="list-style-type: none"> 1. Check delrin guides and properly lubricated (dry graphite spray). 2. Check hydraulic cylinder clevis pins for lubrication (multi-grade grease).
Hydraulic unit is excessively hot	<ol style="list-style-type: none"> 1. Check that the pressure relief valve is closed (fully clockwise) 2. Check that the pressure switch is adjusted to shut the motor off before 1900 PSI 3. Check for correct voltages
Bollard moves too slowly	<ol style="list-style-type: none"> 1. Check for mechanical binds 2. Check flow control valve 3. Extremes cold temperatures
Traffic indicator light does not change	<ol style="list-style-type: none"> 1. Check proper limit switch operation 2. Check bulbs 3. Check PLC outputs

6 WARRANTY

B&B-ARMR CORPORATION warranties for a period of one year, after delivery F.O.B. plant, unless otherwise specified by Supplier, from failure of operation in ordinary use and against defects due to faulty material or workmanship. Any defective equipment in the Barrier shall be returned to the factory, at Supplier's option, for repair or replacement, and Supplier assumes no responsibility for service at any consumer site. Supplier is in no event responsible for any labor costs under the warranty. Subject to the above limitation, all service, parts, and replacements necessary to maintain the equipment as warranted shall be furnished by the end user. Supplier shall not have any liability under these specifications, other than for repair or replacement as described above for equipment malfunction or equipment failure of any kind, caused for any reason, including, but not limited to unauthorized repairs, improper installation, installation not performed by Supplier personnel, nor by Supplier authorized personnel, failure to perform manufacturer's suggested routine maintenance, modifications, misuse, accident, catastrophe, neglect, natural disaster, act of God or if at any time the power supplied to any part of the Security Barrier falls short or exceeds the rate of tolerance for the equipment.

The exclusive remedy for breach of any warranty by Supplier shall be the repair or replacement at supplier's option, of any defects in the equipment. **IN NO EVENT SHALL THE SUPPLIER OF SECURITY BARRIER BE LIABLE FOR CONSEQUENTIAL OR SPECIAL DAMAGES OR ANY KIND OF DAMAGES TO ANYONE.** Except as provided herein, Supplier makes no warranties or representations to consumer or to anyone else and consumer hereby waives all liability against Supplier as well as any other person for the design, manufacture, sale, installation, and/or servicing of the Security Barrier.

THE FOREGOING WARRANTIES ARE IN LIEU OF ALL OTHER WARRANTIES EXPRESS OR IMPLIED, INCLUDING THE IMPLIED WARRANTY OF MERCHANTABILITY AND FITNESS FOR A PARTICULAR PURPOSE. NO OTHER WARRANTIES EXIST.

Any modification or alteration by anyone other than B&B-ARMR will render the warranty herein as null and void.

7 APPENDIX

7.1 Semi-Automatic Parts Breakdown

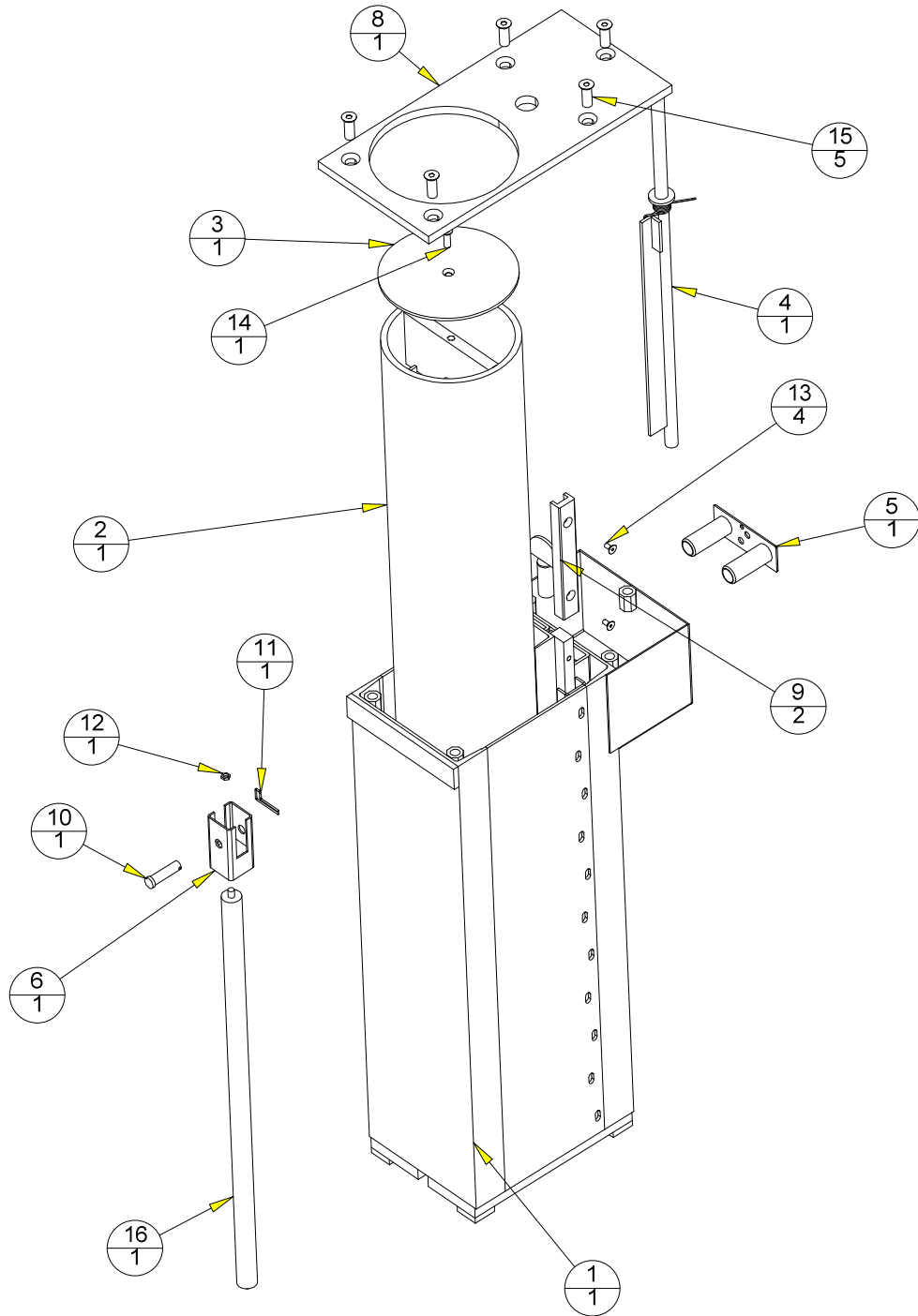

1	16	XSHOCK-3902 -2 , GS3902 -2	GAS SHOCK , INDUSTRIAL GAS SPRING	
5	15	XBOLT-1215 , 3/4-10 X 1.5" LNG , FSH	3/4 10 X 1.5" LONG , FLATHEAD SOCKET DRIVE	
1	14	XBOLT-0815 , 1/2-13 X 1.5" LNG , FSH	1/2- 13 X 1.5" LONG , FLATHEAD SOCKET DRIVE	
4	13	XBOLT-0607 , 3/8-16 X .75" LNG , SST	3/8- 16 X .75" LONG , FLAT, SOCKET DRIVE SST	
1	12	HEXNUT_M10 , MCMASTER90710 A125	HEX NUT M 10- 1.5 MM, STAINLESS	
1	11	COTTERPIN_34 , MCMASTER92391 A155	COTTER PIN, 3/4" DIAMETER SHAFT	
1	10	CLEVISPIN_34 , MCMASTER92390 A527	CLEVIS PIN , 3/4" DIA	
2	9	B30-3129	GUIDE STRIP DELRIN B 30-BOLLARD	
1	8	B30-3226	COVER PLATE SEMI-AUTOMATIC B30-BOLLARD	
1	7	B30-2-201	KEY VEHICLE BARRIER	
1	6	B30-2203	YOKE ASSEMBLY, SHOCK B30-BOLLARD	
1	5	B30-2147	COLLISON PIN ASSEMBLY B 30-BOLLARD	
1	4	B30-2116	LOCKING MECHANISM WELDMENT ASSEMBLY B30-BOLLARD	
1	3	B30-2110	TUBE COVER PLATE ASSEMBLY B30-BOLLARD	
1	2	B30-2106	CYLINDER WELDMENT ASSEMBLY B30-BOLLARD	
1	1	B30-2101	HOUSING WELDMENT B 30-BOLLARD	
QTY	FIG NO	PART OR IDENTIFYING NUMBER	NOMENCLATURE OR DESCRIPTION	NOTES

7.2 Equipment Maintenance Log Form

Product Type: _____

B&B ARMR
800-367-0387



Location: _____

servicedept@bb-armr.com

	Date	Performed By	Checklist Complete	Anomalies	Notes
Jan			Yes No		
Feb			Yes No		
Mar			Yes No		
Apr			Yes No		
May			Yes No		
Jun			Yes No		
Jul			Yes No		
Aug			Yes No		
Sep			Yes No		
Oct			Yes No		
Nov			Yes No		
Year			Yes No		

7.3

	Date	Performed By	Checklist Complete	Anomalies	Notes
Jan			Yes No		
Feb			Yes No		
Mar			Yes No		
Apr			Yes No		
May			Yes No		
Jun			Yes No		
Jul			Yes No		
Aug			Yes No		
Sep			Yes No		
Oct			Yes No		
Nov			Yes No		
Year			Yes No		